

FORK MOUNTED VACUUM LIFTING ATTACHMENT

FMVLA

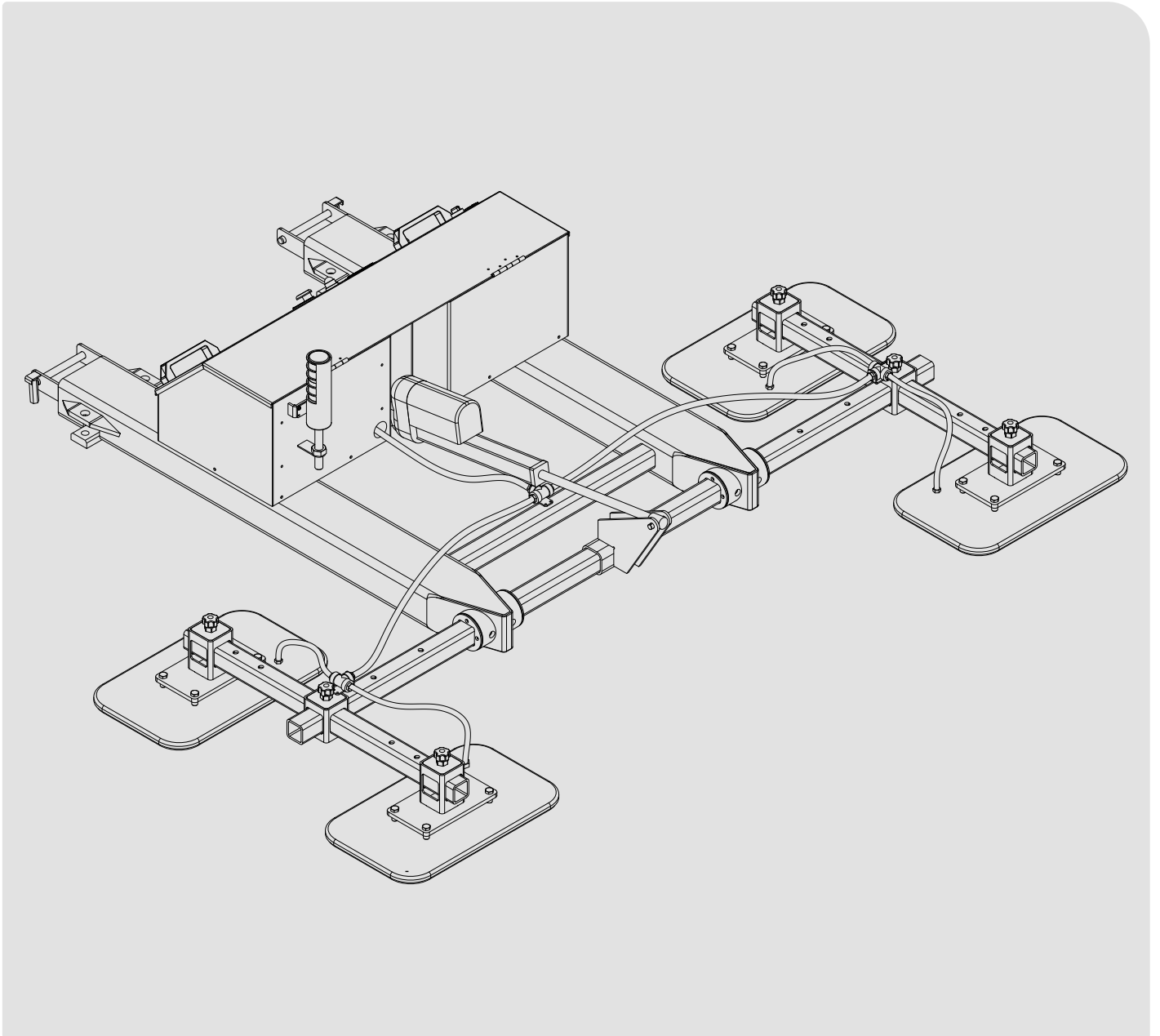

CREATED BY

AARDWOLF INDUSTRIES
Marketing Department

Published on:
November 2024

Contact us:  info@aardwolf.com.au
 www.aardwolf.com.au



INDEX

Page

01 OVERVIEW

Introduction	04
Dimensions, Specifications	05
Drawing	06
Parts list	07

02 SAFETY INSTRUCTIONS

General	08
Warnings	09

03 ASSEMBLY

10

04 USER INSTRUCTIONS

Understanding the control buttons	10
Operating the Lifter	11

05 MAINTENANCE

Maintenance schedule	12
Vacuum filter maintenance	12
Vacuum pad maintenance	12

06 PREVENTIVE MAINTENANCE CHECKLIST

13

07 TROUBLESHOOT

14

08 WARRANTY

15

Dear Customer,

Thank you for choosing the **Aardwolf Fork Mounted Vacuum Lifting Attachment – FMVLA**.

Please read the manual carefully before use and keep it readily accessible beside the vacuum lifter at all times.

If you have any questions, require spare parts, or need to report any issues, please contact the Aardwolf distributor at your location, provide the product code and serial number, and send them to ***info@aardwolf.com.au*** for assistance.

We hope this advanced tool meets your needs and exceeds your expectations.

Best regards,

Aardwolf Industries

 info@aardwolf.com.au

 www.aardwolf.com.au

01 OVERVIEW



INTRODUCTION

Designed for transporting heavy slab materials such as wood sheets, metal sheets, composite sheets, and concrete slabs, the FMVLA offers a remote-controlled with 90-degree rotation, capable of lifting materials up to 1000 kg (2204 lbs) with 3 meters (118 in) in length. It features an automatic pressure control system, a visual gauge, and adjustable vacuum pads position, emphasizing safety, precision, and performance. Powered by a battery compliant with Australian standards, this attachment provides consistent and effective material handling solutions.

Key features

✦ High Capacity

Supports up to 1000 kg (2204 lbs) horizontally for slabs with 3 meters (118 in) long and 2 meters (79 in) wide.

✦ 90-Degree Maneuverability

Features remote-controlled with 90-degree rotation for optimal positioning.

✦ Adjustable Vacuum Pads

Easily adaptable to different material sizes for enhanced operational flexibility.

✦ Automatic Pressure Control

Maintains optimal vacuum pressure for increased safety.

✦ Dependable Power

Operates on a 24V-100A battery that meets Australian Standard AS4991-2004.

✦ Audio/Visual Gauge and Alarm System

Ensures smooth and safe operation with an integrated remote controller.



DIMENSIONS

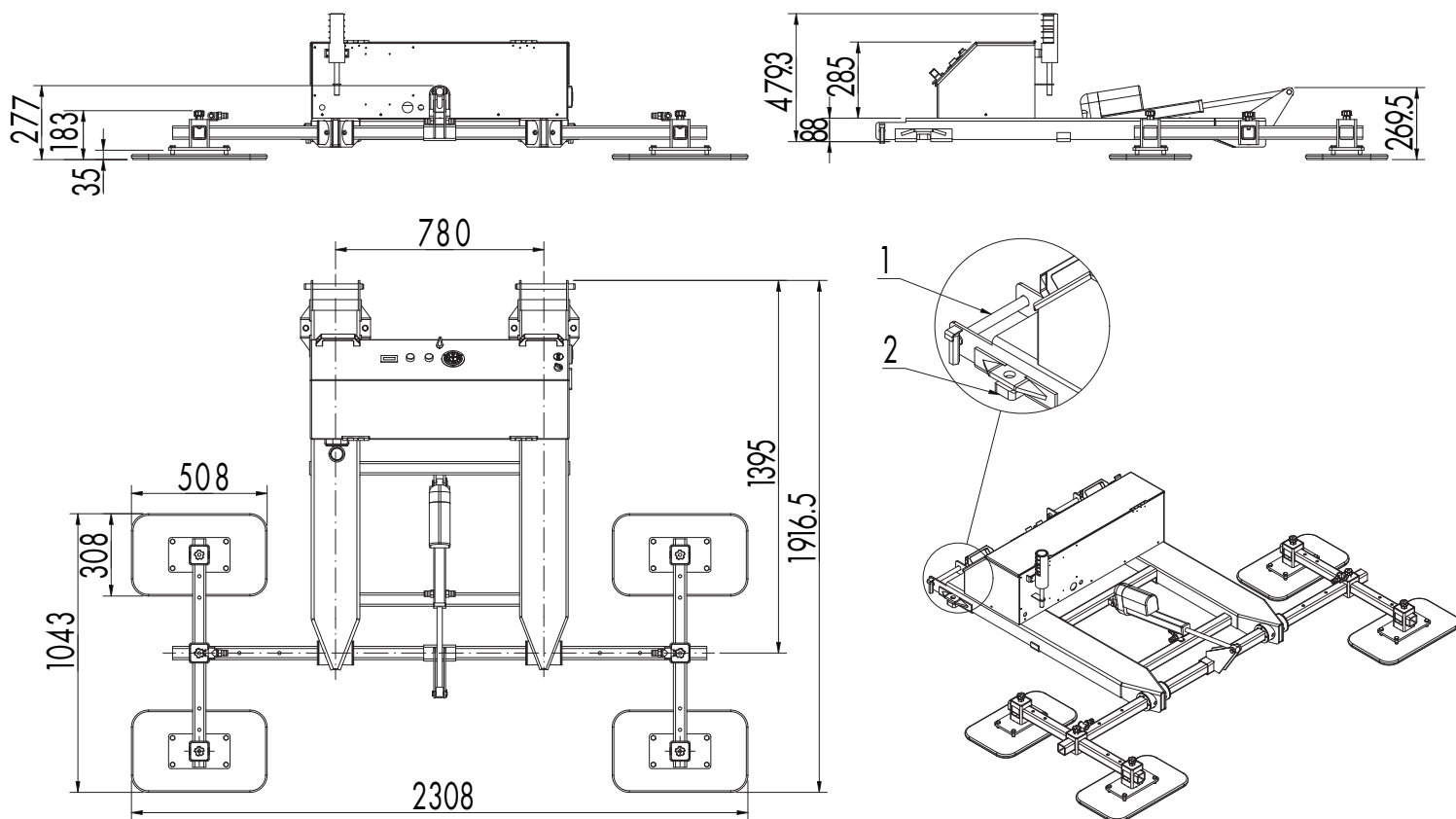

SPECIFICATIONS

FMVLA	
Number of pads	4
Pad sizes	500 x 300 mm 19.7" x 11.8"
Working load limit	760 kg / 1676 lbs
<ul style="list-style-type: none"> Vertical Horizontal 	1000 kg / 2204 lbs
Net weight	220 kg / 485 lbs
Gross weight	290 kg / 639 lbs
Packaging dimensions	2270 x 1710 x 630 mm 89.4 x 67.3 x 24.8 in

BATTERY INFORMATION

Power supply	24V-100Ah Lithium battery
Charging requirements	24V-22A
Standby time	>100 hours
Charging cycle	1000 times
Charging time	5 hours
Vacuum pump's continuous working time	3 hours

MOTOR INFORMATION

Model: THOMAS - VTE 10	Flow: 10 m ³ /h
Motor: 24V AC - 30A	Vac.: 150 mbar abs

DRAWING - FMVLA

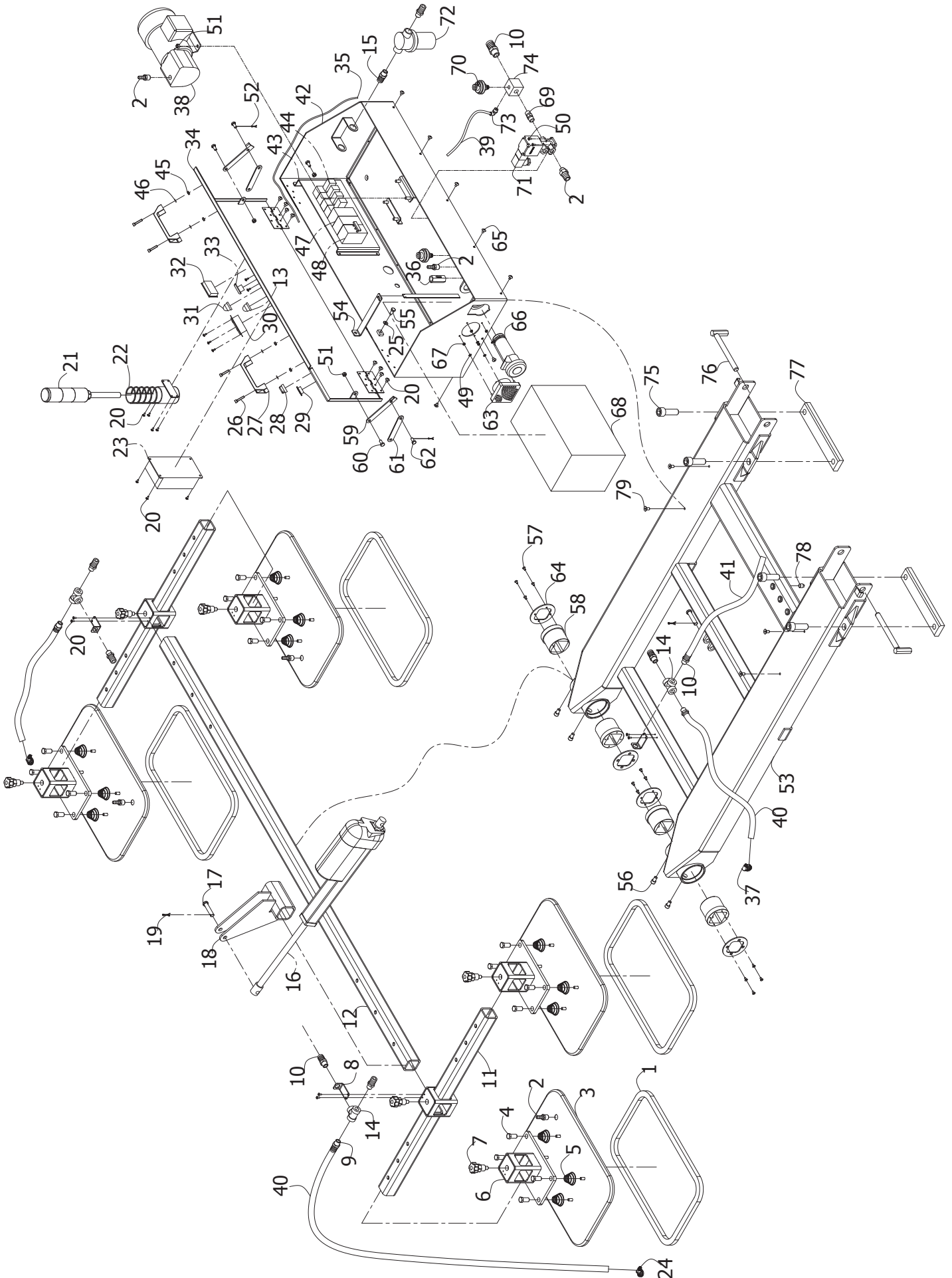

PARTS LIST - FMVLA

POS.	DESCRIPTION	Q'TY
01	Seal 500x300	04
02	Straight Fitting Tube Ø3/8" - Thread G1/4"	04
03	Hub 500x300	04
04	Pin Ø13.5, L=26mm	16
05	Helical Spring	16
06	Pad bracket	04
07	Locking pin	06
08	Bracket	03
09	Straight Fitting Tube Ø3/8" - Thread G3/8"	05
10	Straight Fitting Tube Ø3/4" - Thread G3/8"	06
11	Vertical Bar	02
12	Horizontal Bar	01
13	Red light	01
14	Tee Connector G 3/8"	03
15	Straight Fitting Tube Ø3/4" - Thread G1/2"	02
16	Electric Actuator 24V, L=300mm	01
17	Pin Ø12	02
18	Lever	01
19	Split Pin Ø12	02
20	Truss Head Cap Screw M4x10	25
21	Signal Light	01
22	Signal Light Bracket	01
23	Remote Control Box	01
24	Plastic Tube Ø 3/8" Clamp	24
25	Washer M8	01
26	Socket Head Cap Screw M6x30	04
27	Handle	02
28	Selector Switch	01
29	Power Button	01
30	Vacuum Gauge	01
31	Green Light	01
32	Battery Gauge	01
33	Locking A19-1-2	01
34	Lid	01
35	Edge Trim, L=3000 mm	01
36	Check Valve	01
37	Plastic Tube Ø 3/4" Clamp	16
38	Vacuum Pump	01
39	Plastic Tube Ø6, L=300 mm	01
40	Plastic Tube Ø 3/8 x 5000 mm	01

POS.	DESCRIPTION	Q'TY
41	Plastic Tube Ø 3/4" x 3000 mm	01
42	Electric Box Enclosure	01
43	Electric Component Bracket	01
44	Relay_1	04
45	Nut M6	04
46	Washer M6	04
47	Relay_2	02
48	CB	01
49	Washer M4	14
50	Socket Head Cap Screw M4x10	09
51	Nut M8	08
52	Split Pin Ø6	02
53	Main Frame	01
54	Battery Clamping	01
55	Socket Head Cap Screw M8x16	01
56	Socket Head Cap Screw M10x20	04
57	Countersunk Head Screw M4x10	16
58	Plastic Bushing	04
59	Linking Pad_1	02
60	Bolt M8x20	04
61	Linking Pad_2	02
62	Pin Ø6	02
63	Alarm	01
64	Plastic Bushing Cover	04
65	Trus Head Cap Screw M6x15	12
66	Electric Socket	01
67	Nut M4	04
68	Battery 24V-100AH	01
69	Nipple Male Thread G3/8" - G3/8"	01
70	Pressure Switch	02
71	Solenoid Valve 24V	01
72	Filter ABF-15	01
73	Air Hose Ø6 Male Thread G1/8"	01
74	Divider	01
75	Socket Head Cap screw M20x40	04
76	Locking Pin	02
77	Locking Pad	02
78	Plugging Bolt G1/4"	01
79	Countersunk Head Screw M8x10	04

02 SAFETY INSTRUCTIONS



GENERAL

PREPARATION

✦ Training

The operator must be trained and possess the necessary knowledge, skills, and expertise in all relevant industry and regulatory standards for operating the Lifter in their geographical location.

✦ Load Specifications

Ensure the load is a single load with a smooth, non-porous surface and does not exceed the W.L.L.

✦ Surface Safety

Do not attach the suction pad to slippery surfaces where the load could slide off.

PRE-USE CHECKS

✦ Vacuum Pad

Check that the vacuum pad surface is clean and free from dirt and oil.

✦ Obstructions

Ensure there are no obstructions during operation.

✦ Battery Levels

Always check battery levels before lifting the load.

✦ Tests

Perform load, vacuum, and pumping tests to ensure the Lifter works well.

OPERATING INSTRUCTIONS

✦ Placement

Center the Lifter on the load.

✦ Personnel

Only competent and authorized personnel should operate the Lifter.

✦ Protective Equipment

Operators must always wear appropriate protective equipment.

✦ Environment Conditions

Avoid operating in unpleasant, poor quality, or hazardous physical environments.

SAFETY PRECAUTIONS

✦ Load Handling

Never lift a load over people. Ensure no one is under the load during lifting.

 **Power Source**

Power off the Lifter when not in use.

 **Damaged Equipment**

Do not operate the Lifter that is damaged, malfunctioning, or missing parts.



WARNINGS

Always

Ensure that the operator is fully trained and possesses the necessary knowledge, skills, and expertise in all relevant industry and regulatory standards specific to operating the Lifter in their geographical location.

Wear personal protective equipment.

Use one load per operation.

Check for Damage: Always inspect the Lifter for damage, malfunctioning parts, or missing components before each use.

Maintain Clean Surfaces: Always ensure that the contact surfaces of the load and all vacuum pads are clean before applying the pads.

Power Source: Always ensure the power source is available throughout the entire lifting operation.

Use Appropriate Load Characteristics: Always ensure the load is within the specified W.L.L.

Conduct Regular Maintenance: Always perform regular inspections and maintenance as outlined in the manual to ensure the Lifter is in good working condition.

Follow Operating Procedures: Always follow the specified operating procedures when lifting, rotating, or moving loads.

Never

Operate a Damaged Lifter: Never operate the Lifter that is damaged, malfunctioning, or missing parts.

Exceed W.L.L.: Never exceed the Lifter's W.L.L. or attempt to lift loads it is not designed for.

Lift Unstable Loads: Never attempt to lift a cracked or broken load.

Operate Without Clean Pads: Never use the Lifter if any vacuum pad's sealing edge foam seal is cut, damaged, or contaminated.

Remove Warning Labels: Never remove or obscure any warning labels on the Lifter.

Touch Vacuum Release Buttons: Never touch the vacuum release buttons during a lift, as this may result in the release of the load.

Lift Over People: Never lift a load over people or allow people to ride on the Lifter or the load.

Leave Suspended Loads Unattended: Never leave a suspended load unattended or lift it higher than necessary.

Modify the Lifter: Never modify the Lifter, as modifications may compromise its safety and performance.

Use in Dangerous Environments: Never use the Lifter in inherently dangerous environments or likely to compromise its ability to function, such as areas containing explosives or caustic chemicals.

Never release the handle while lifting.

03 ASSEMBLY

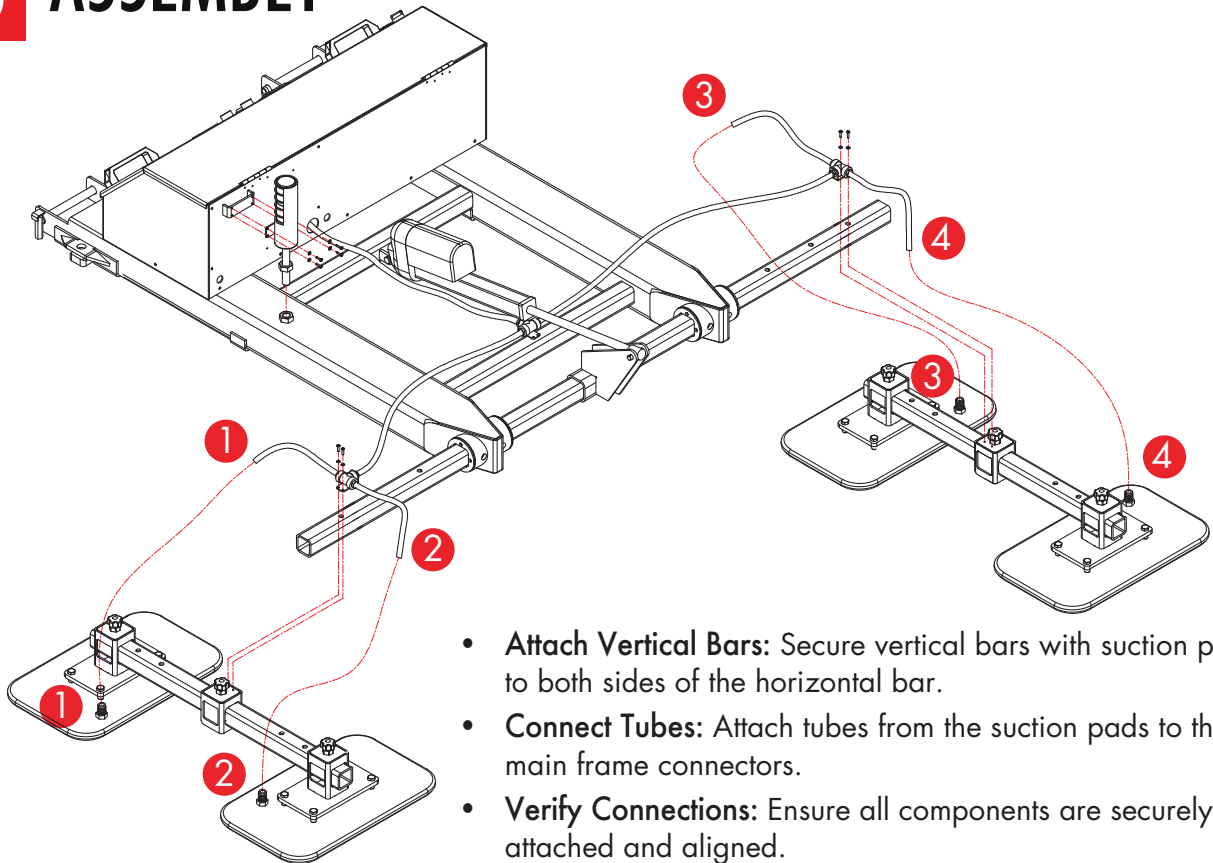

- **Attach Vertical Bars:** Secure vertical bars with suction pads to both sides of the horizontal bar.
- **Connect Tubes:** Attach tubes from the suction pads to the main frame connectors.
- **Verify Connections:** Ensure all components are securely attached and aligned.

04 USER INSTRUCTIONS



UNDERSTANDING THE CONTROL BUTTONS

Manual Control

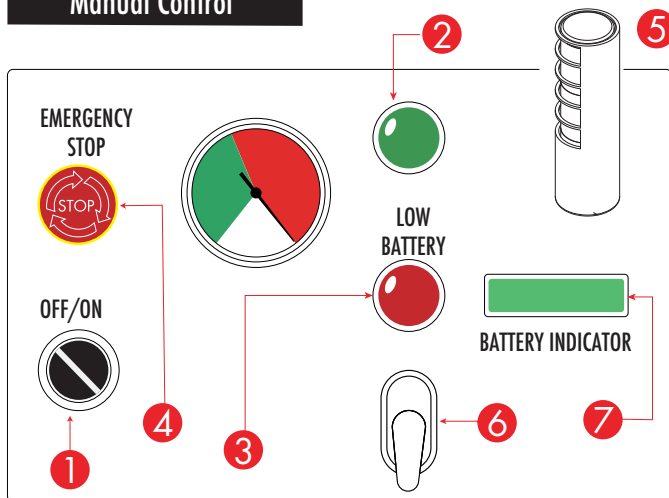

1. **POWER ON/OFF**
Controls the Lifter's power.
2. **GREEN POWER INDICATOR**
Indicates that the power is on.
3. **RED BATTERY INDICATOR**
Indicates that the battery is low.
4. **EMERGENCY STOP**
Disables the remaining buttons on the Control Panel.
5. **ALARM SYSTEM**
Displays the current battery level of the Lifter.
6. **ACCESS KNOB**
Opens the Electric Box when needed.
7. **LED MONITOR**
Displays the current battery level of the Lifter.

5. ALARM SYSTEM

- The green light indicates that the equipment is ready for safe operation.
- The red light and horn sound indicate a warning that the vacuum pressure is insufficient.

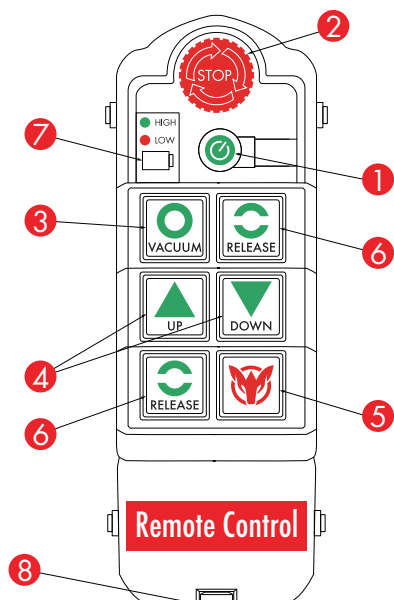

1. **POWER ON KEY:** Activates the remote.
2. **EMERGENCY STOP:** Disables the remaining buttons on the remote control.
3. **VACUUM:** Activates the vacuum to inhale materials.
4. **UP – DOWN:** Adjusts the tilt of materials for precise positioning.
5. **DROP:** Checks the remaining battery status in FMVLA.
6. **RELEASE:** Must be pressed simultaneously to safely disengage the vacuum.
7. **BATTERY INDICATOR:** Shows the current battery level of the remote.
8. **BATTERY:** 6V battery



OPERATING THE LIFTER

1 Prepare the Lifter

Unlock and open the electric box with the Access Knob, turn on the Control Panel (CP), and ensure the LED Monitor lights up. Lock the box after activation.

2 Secure Attachment

Attach the Forklift to the Lifter's Main Frame securely using the Socket Head Cap Screw and the Locking Pin.

3 Power on the Lifter

The horn will sound, the Red Power Indicator will light up, and the vacuum pump will start. When the Green Light is on, the system is ready.

4 Position Lifter

Center the Lifter over the load.

5 Engage Suction

Press the "VACUUM" button. Ensure the Pressure Gauge Needle is in the green zone, and the green light is on.

6 Adjust Height

Use the forklift's hydraulic control to lift or lower the load.

7 Tilt Load

Press the "UP" and "DOWN" buttons to adjust the load tilt.

8 Place and Release Load

Move the load to the desired location and release the suction by simultaneously pressing the two "RELEASE" buttons on the Remote Control.

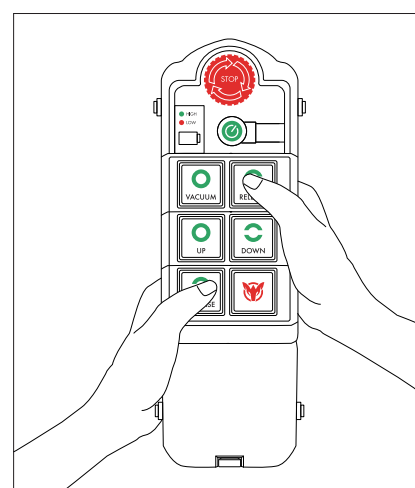

*Release load by
Remote Control*

05 MAINTENANCE



MAINTENANCE SCHEDULE

A maintenance schedule is crucial for keeping equipment in optimal condition. It specifies routine tasks like inspections, cleaning, and part replacements at regular intervals. Following this schedule helps prevent breakdowns and extend equipment lifespan.



VACUUM FILTER MAINTENANCE

Clean

- ✦ Use a soft brush or compressed air to remove debris.

Inspect and Replace

- ✦ Check for signs of damage, such as tears or holes, and replace the filter if it is significantly worn or damaged.

Installation

- ✦ Turn off the vacuum pump before performing any maintenance.
- ✦ Ensure the filter is dry and properly aligned before placing it back into the housing.



VACUUM PAD MAINTENANCE

Placement

- ✦ Do not place suction pads on the floor or other surfaces when not in use to prevent the vacuum blower's uncontrolled movements and potential overheating.

Clean

- ✦ Avoid using solvents, petroleum, gasoline, or harsh chemicals. Stick to mild cleaning solutions.

Protect

- ✦ Use the pad cover when the lifter is not in use to protect the vacuum pad.

Store

- ✦ Keep the pad in dry conditions to prevent damage from moisture.

06

PREVENTIVE MAINTENANCE CHECKLIST

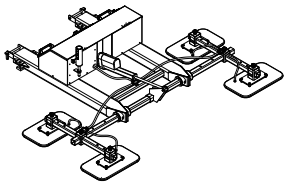

By following maintenance checklists, you can help ensure that your vacuum lifter operates safely and effectively for a long time.

	DAILY CHECKS	WEEKLY CHECKS	MONTHLY CHECKS	ANNUAL CHECKS
Note:	<p>Inspect suction pads for cracks or worn sealing lips.</p> <p>Check the air filter elements for dust and contaminants that could impair performance, clean as needed.</p> <p>Look for signs of wear, damage, or leaks in the pump and its components.</p> <p>Ensure all air hoses and connections are secure and free of leaks.</p>	<p>Test the vacuum pump to maintain suction power at the set level.</p> <p>Verify the functionality of the vacuum gauge. It should be responsive and accurate.</p> <p>Inspect the device's structure and vacuum system for visual damage.</p>	<p>Test the safety alarm and warning systems to ensure they are functional.</p> <p>Inspect the entire device for cracks, cuts, corrosion or any deficiency.</p>	<p>Schedule a professional inspection and certification of the entire unit.</p> <p>Perform a thorough load capacity test to ensure the lifter can safely handle maximum loads.</p> <p>Replace any non-functional parts or those showing excessive wear.</p>

DAY	DATE	CHECKED											
Monday													
Tuesday													
Wednesday													
Thursday													
Friday													
Saturday													
Sunday													
Monday													
Tuesday													
Wednesday													
Thursday													
Friday													
Saturday													
Sunday													

Note: Always refer to the specific maintenance manual provided by the manufacturer for more detailed instructions and safety information related to your particular model.

07 TROUBLESHOOT

PROBLEM	LIKELY CAUSED BY	ACTION REQUIRE
Vacuum pump does not started	Out of batteries	Recharge the battery
The device does not lift or exhibits reduced functionality	Vacuum pump not started	Check the function of the vacuum pump. Ensure it is properly installed and powered on.
	Load too heavy	Reduce the load. Ensure it does not exceed the lifter's maximum lifting capacity.
	Air leakage	Inspect all connections, air hoses for leaks, cracks, holes, or loose hose clamps. Check the filter unit for any leaks. Clean or replace the suction pad if necessary.
	Dirty vacuum pump filter	Clean the filter insert. Refer to the maintenance section on cleaning the vacuum pump filter.
	Dirty vacuum pad	Clean the vacuum pad. Refer to the maintenance section on cleaning the vacuum pad.
	Vacuum Pad Installed Incorrectly	Reinstall the vacuum pad correctly, ensuring the nuts are neither over-tightened nor under-tightened.

Note: For serious issues or additional support, please get in touch with Aardwolf Technician Support at info@aardwolf.com.au. Our experts are ready to assist with any complex problems to ensure your equipment operates smoothly.

08 WARRANTY



PRODUCT CHECK AND REPORTING

Upon receiving the product, the buyer should verify, based on the spare parts list and attached spare drawings, that all spare parts are intact and not lost during shipment. Any damages or losses must be officially reported to Aardwolf Industries within eight days of purchase.



WARRANTY INFORMATION

The Lifter comes with a 12-month warranty from the date of purchase, following Aardwolf Industries warranty policy.



WARRANTY EXCLUSIONS

The warranty coverage does not apply if:

- ✘ The Lifter is handled incorrectly during maneuvering.
- ✘ The user fails to comply with the instructions provided in the manual.
- ✘ The Lifter's maximum W.L.L is exceeded.
- ✘ The specifications for the load thickness are not followed.
- ✘ Damages result from inadequate maintenance and inspections.
- ✘ Damage is due to improper storage.
- ✘ Repairs are performed by the user without permission from Aardwolf Industries.
- ✘ Unofficial spare parts are used.



DECLARATION OF CONFORMITY

We declare that the Lifter conforms to the following standards:

- ✘ The Machinery Directive 2006/42/EC
- ✘ Australian Standard 4991-2004

Note: *It is the user's responsibility to comply with state or local laws. The end user is responsible for using the equipment safely, in the manner it is designed for, and within the unit's rated capacity.*

WE PROVIDE

Simple, Reliable, Cost Saving And
Awesome Ideas For Your Business

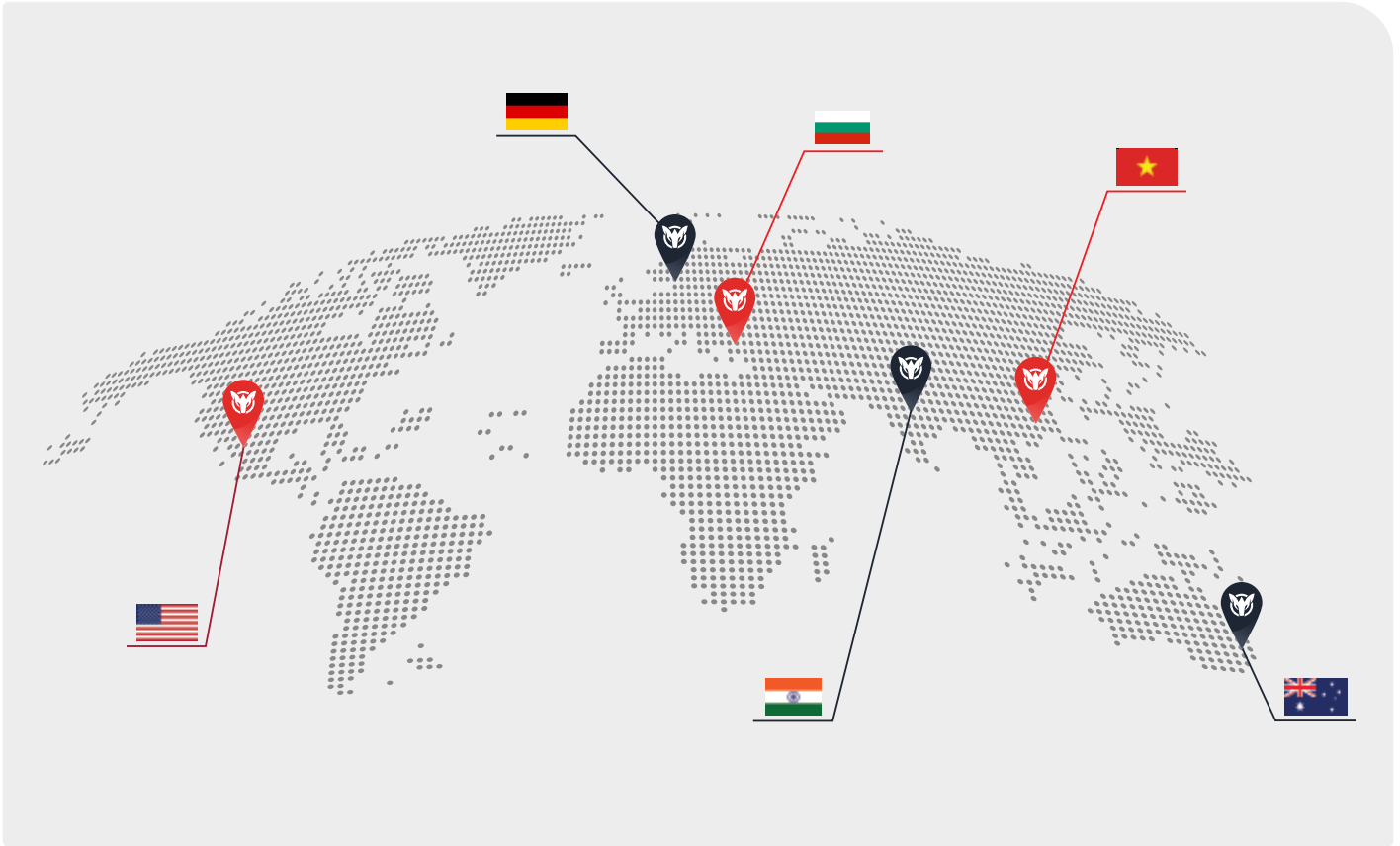

FIND THE NEAREST AARDWOLF SERVICE CENTER

AUSTRALIA

1/5 Stanton Road, Seven Hills NSW 2147
Tel: 02 9838 8427
Email: enquiries@aardwolfaustralia.com
Web: www.aardwolfaustralia.com

INDIA

Harmara Road, Industrial Area, Madanganj, Kishangarh,
District- Ajmer, Rajasthan India 305801
Tel: +91 73000 68444
Email: sales@aardwolf.co.in
Web: www.aardwolf.co.in

BULGARIA

Str.Usta Kolio Ficheto 33
Tel: +359 887 933 754
Email: adrian@toolrange.com

USA

9401 Norwalk Blvd, Santa Fe Springs, CA 90670
Tel: (562) 553-6050
Email: sales@aardwolfusa.com
Web: www.aardwolfusa.com

GERMANY

Schulze-Delitzsch-Weg 2, 33175 Bad Lippspringe
Tel: 05252 8382830
Email: sales@aardwolf.com.de

VIETNAM

1B, An Phu, Thuan An City, Binh Duong Province, Vietnam
Tel: +84 931 707 793
Email: infot@aardwolf.com.au
Web: www.aardwolf.com.au

